

Grand Promerix

Powerful Grand Promerix operating table for demanding surgical procedures

Grand Promerix operating table is a heavy-duty, yet versatile operating table for all kind of surgical procedures. Well-designed details help you work more fluently. Grand Promerix operating table is excellent for bariatric surgeries. Grand Promerix operating table is designed according to the **Merivaara Design DNA concept**. The Merivaara Design DNA includes key elements that ensure that Grand Promerix operating table is easy to use, easy to clean and easy to understand. Merivaara Design DNA reflects modern, customer-oriented functionality that focuses only on what is essential for the users – the user experience itself. Read more about the [Merivaara Design DNA concept](#). Grand Promerix operating table has also a Design from Finland mark awarded to companies that have evidence of excellence in Finnish design. The products and solutions using this mark are designed to be professional, user-friendly, and sustainable. Read more about the [Design from Finland mark](#).

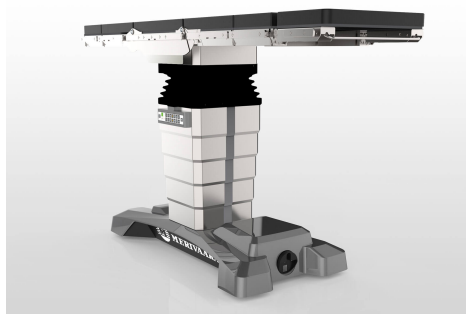
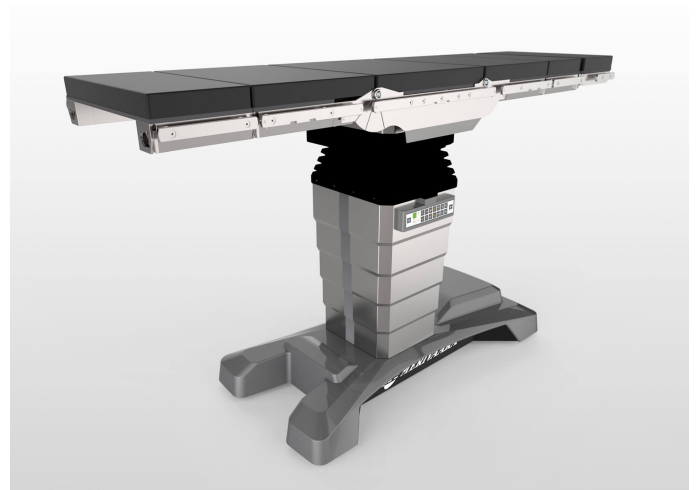

Highlights

Improved ergonomic design improves the comfort of the whole surgical team. Comfort leads to concentration, confidence and better co-operation. That's efficiency.



- 1. Fluent design language connects Grand Promerix seamlessly to Merivaara product family**
- 2. Hidden, smaller castors - improved ergonomics**
- 3. Inwards cutout - increased foot space**
- 4. Increased C-arm access**
- 5. Base cover also available in stainless steel**
- 6. Column casings with chamfered edges**
- 7. Bellows designed for easy clean**

Benefits of the Grand Promerix operating table

1. IMPROVED ERGONOMICS

Grand Promerix has lots of improved details for better ergonomics, for example, hidden, smaller castors and a curved cutout for increased foot space. Human-centric design at its best.

2. C-ARM ACCESS

The renewed slim base gives you perfect C-arm access. The Grand Promerix is designed to meet the highest standards in the operating room.

3. INCREASED HYGIENE

Details redesigned with patient safety in mind. New bellows & seat section, among other improvements, make Grand Promerix hygienic and easy to clean.

4. FLUENT LOCK™

Our Fluent locking system is both user-friendly and reliable. Connect with one click.

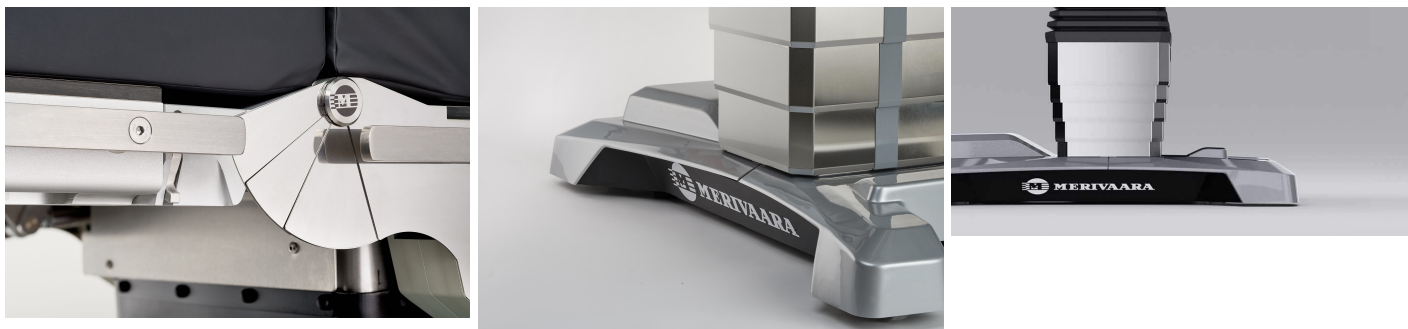

TECHNICAL SPECIFICATIONS

	Sliding	Non-sliding
Length (table top)	2100 mm	2100 mm
Width (table top)	540 mm	540 mm
Width (base)	652 mm	652 mm
Height adjustment	650-1110 mm	610-1070 mm
Max. patient weight	275 kg	325 kg
Safe working load (SWL)	275 kg	325 kg
Trendelenburg	-35°	-35°
Reverse Trendelenburg	+35°	+35°
Head rest adjustment	-45 - +45°	-45 - +45°
Back section adjustment	-45 - +80°	-45 - +80°
Leg section adjustment	-105 - +70°	-95 - +70°
Castors size	80 mm	80 mm
Frequency	47-63 Hz	47-63 Hz
Input voltage	100-240 VAC	100-240 VAC
Weight	325 kg	300 kg
Longitudinal shift of the table top	410 mm	
Lateral tilt	-25 - +25°	20 - 20°
Lower frame length	1317 mm	1317 mm
Floor clearance	25 mm	25 mm
Max. lifting capacity	490 kg	490 kg
Product Code	100060000	100060000
Official product name	Promerix	Promerix

Contact us

Merivaara Corp.
Tarmontie 2-4
15860 HOLLOLA
FINLAND

+358 3 3394 611

merivaara@merivaara.com